



HEPAire FAN FILTER UNIT—115V

Project # Date:

Quote # Customer Ref #

STANDARD FEATURES

- Anodized aluminum framed 63mm (2.5") HEPA filter pack with painted protective screen downstream
- Minimum HEPA filter efficiency 99.99% at 0.30 microns
- Backward curved centrifugal fans
- Variable speed control with on/off to help increase HEPA filter life cycle
- MERV 8 pleated pre-filters, 100% synthetic media that does not support microbial growth
- Standard 9-foot 3-prong electrical cord for quick connections
- Filter housing manufactured from durable light-weight 16-gauge aluminum with sealed edges

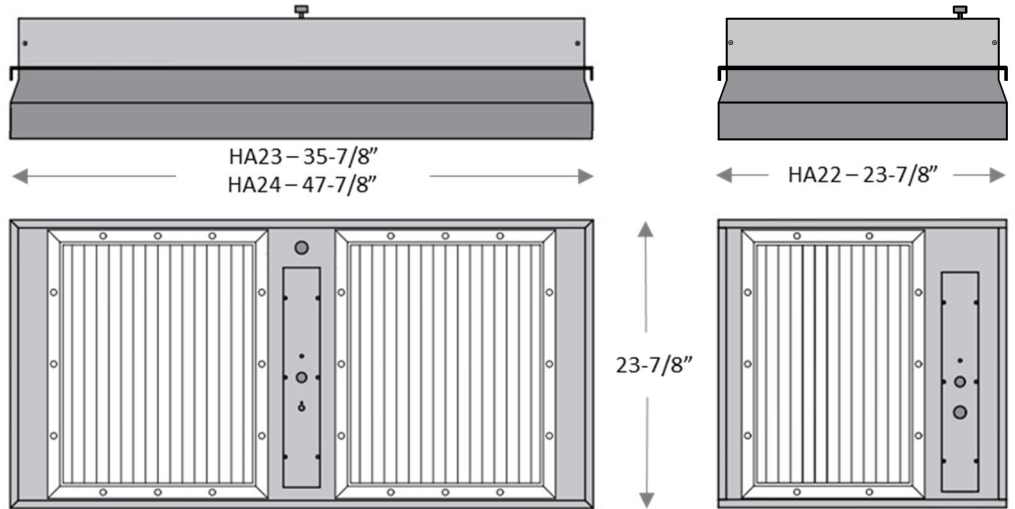

OPTIONAL ACCESSORIES

- Powder coated filter housing
- HVAC collar connection
- Suspension hardware
- Tamper-proof speed control cover
- Down stream gasket for T-grid installation
- High Capacity MERV 10 pre-filter in lieu of MERV 8

| Qty | Model | Dimensions | Electrical (FLA listed) | Weight |
|-----|------------|-----------------------------|-------------------------|--------|
| | HA24-01-01 | 23-5/8" x 47-5/8" x 10-7/8" | 115V, 2.16A, 60Hz | 47bs |
| | HA23-01-01 | 23-5/8" x 37-5/8" x 10-7/8" | 115V, 2.16A, 60Hz | 43lbs |
| | HA22-01-01 | 23-5/8" x 23-5/8" x 10-7/8" | 115V, 1.08A, 60Hz | 28lbs |

Customer Approval _____

Date: _____

