



VERTICAL FLOW WORKSTATIONS

Project # Date:

Quote # Customer Ref #

STANDARD FEATURES

- Provides better than ISO-5 conditions
- HEPA Filter rated minimum 99.99% efficient at 0.3 microns
- Low energy costs
- Standard LED light fixture
- Variable speed control to help increase HEPA filter life cycle

AVAILABLE OPTIONAL ACCESSORIES

BASE FRAMES

- No Base
- 30" sitting height
- 36" standing height
- Casters to form mobile base

FACE SHIELD

- No Face Shield—standard
- Hinged

OPTIONAL ACCESSORIES

- Stainless steel back & side panels
- Pass-thru Grommets on side panels
- Pass-thru Grommets on back panel
- Front and side Facia panels

WORK SURFACES

- Phenolic Resin
- Stainless Steel

DUPLEX OUTLET

- Left rear panel
- Left side panel
- Right rear panel
- Right side panel

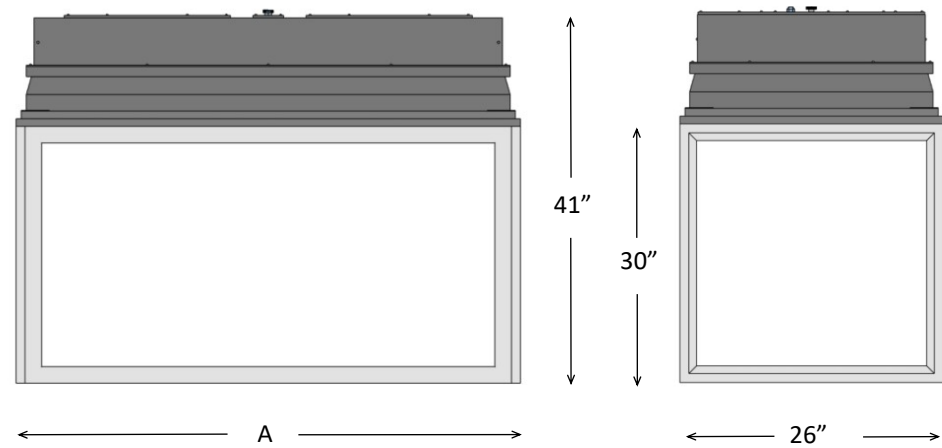

| Qty | Model | Dimension A | Actual Dimensions W x D x H | Electrical Requirements |
|-----|-------|-------------|-----------------------------|--------------------------|
| | VVF-2 | 24" | 26" x 26" x 41" | 2.30-amps, 115V, 50/50Hz |
| | VVF-3 | 36" | 38" x 26" x 41" | 4.52-amps, 115V, 50/50Hz |
| | VVF-4 | 48" | 50" x 26" x 41" | 4.52-amps, 115V, 50/50Hz |
| | VVF-5 | 60" | 63" x 26" x 41" | 6.82-amps, 115V, 50/50Hz |
| | VVF-6 | 72" | 75" x 26" x 41" | 9.04-amps, 115V, 50/50Hz |

Customer Approval _____

Date: _____